

5

10

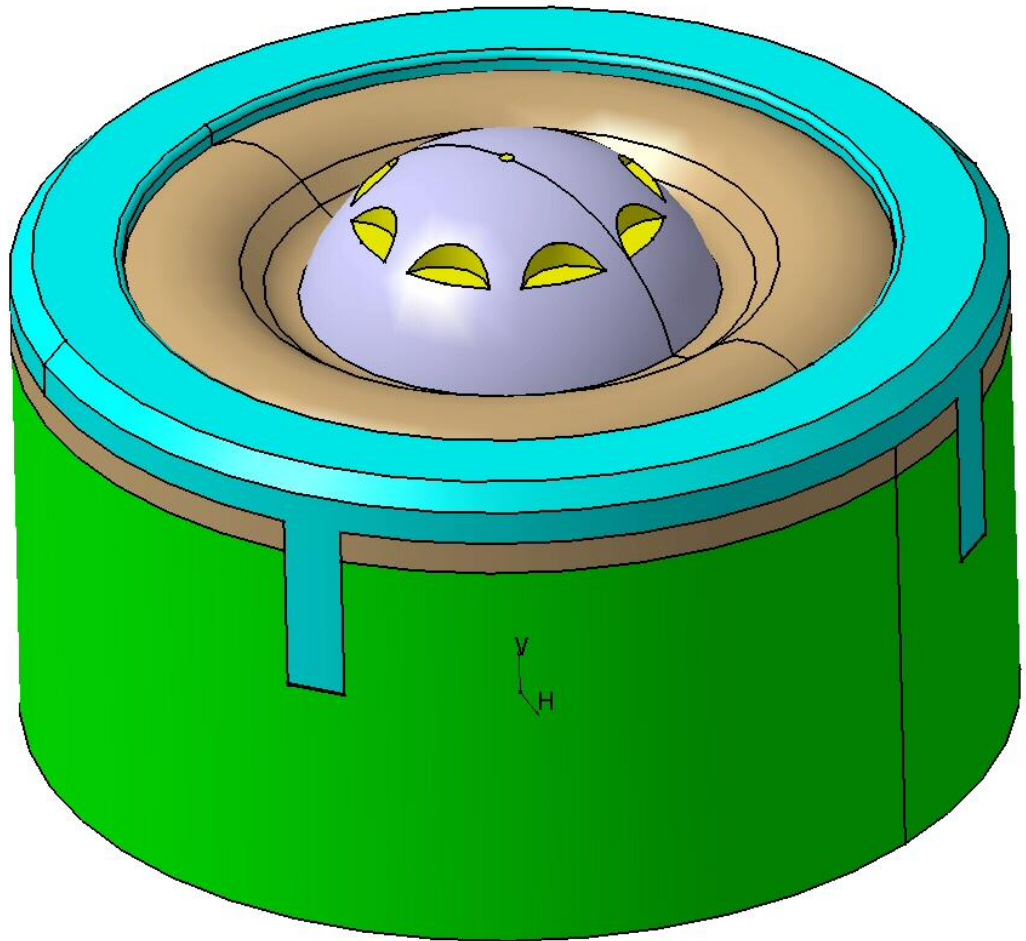

15

20

5

10

15

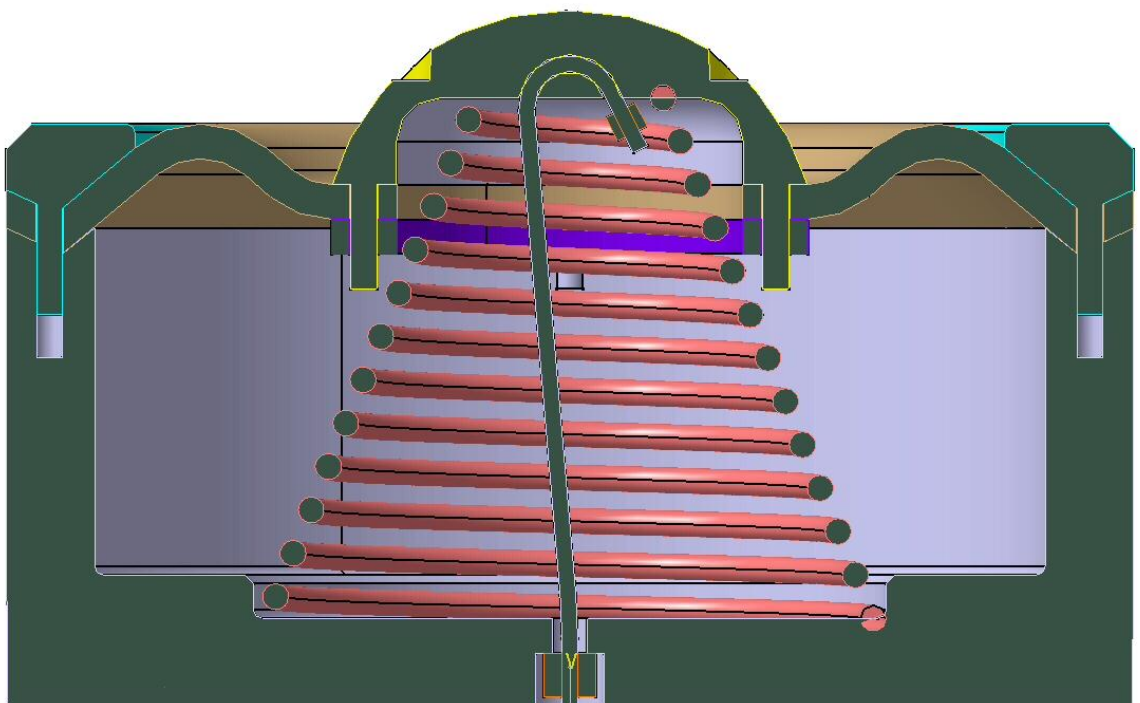

20

25

5

10

15

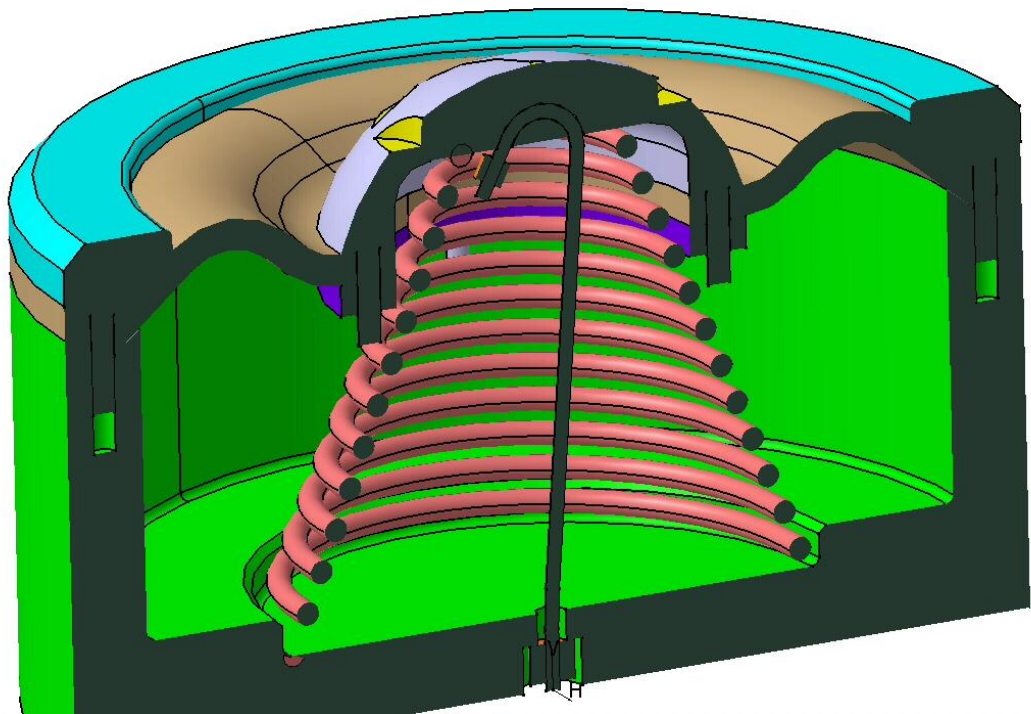

20

25

5

10

15

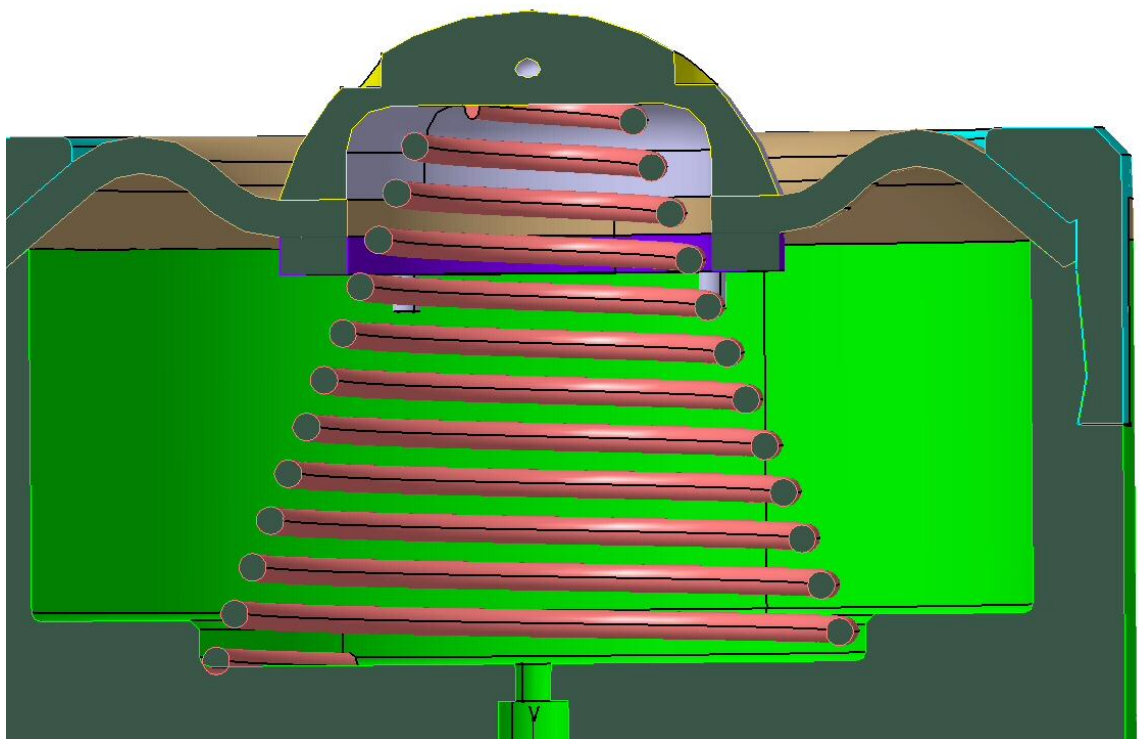

20

25

5

10

15

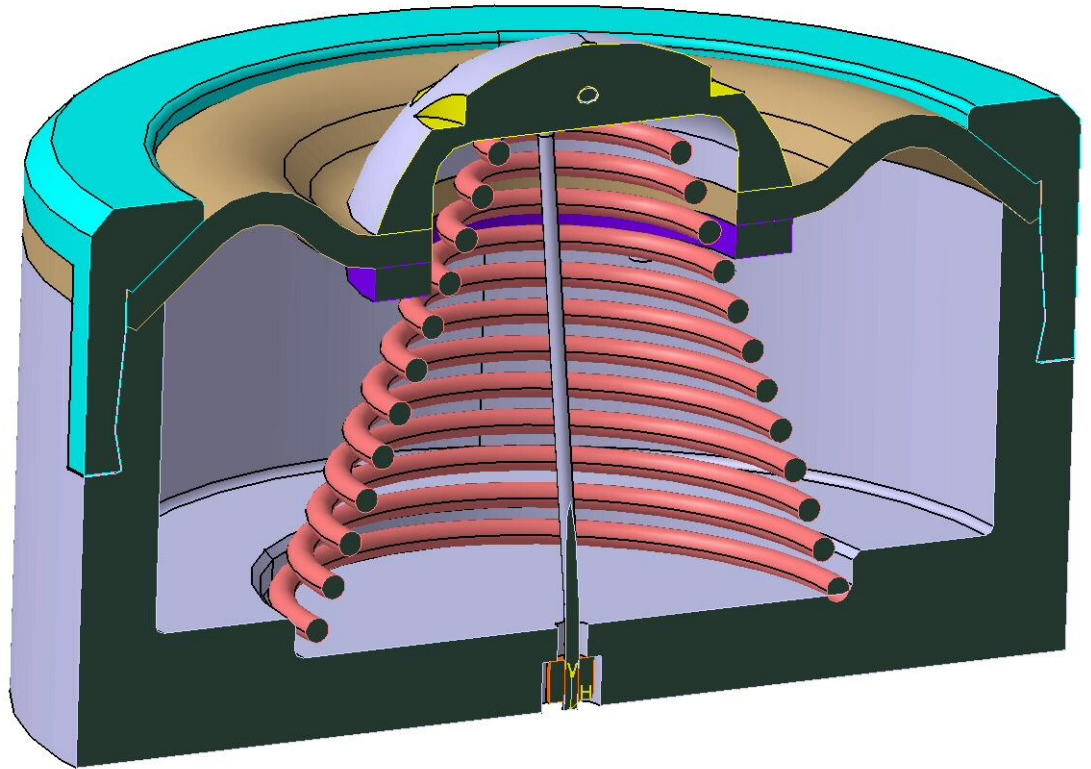

20

25

5

10

15

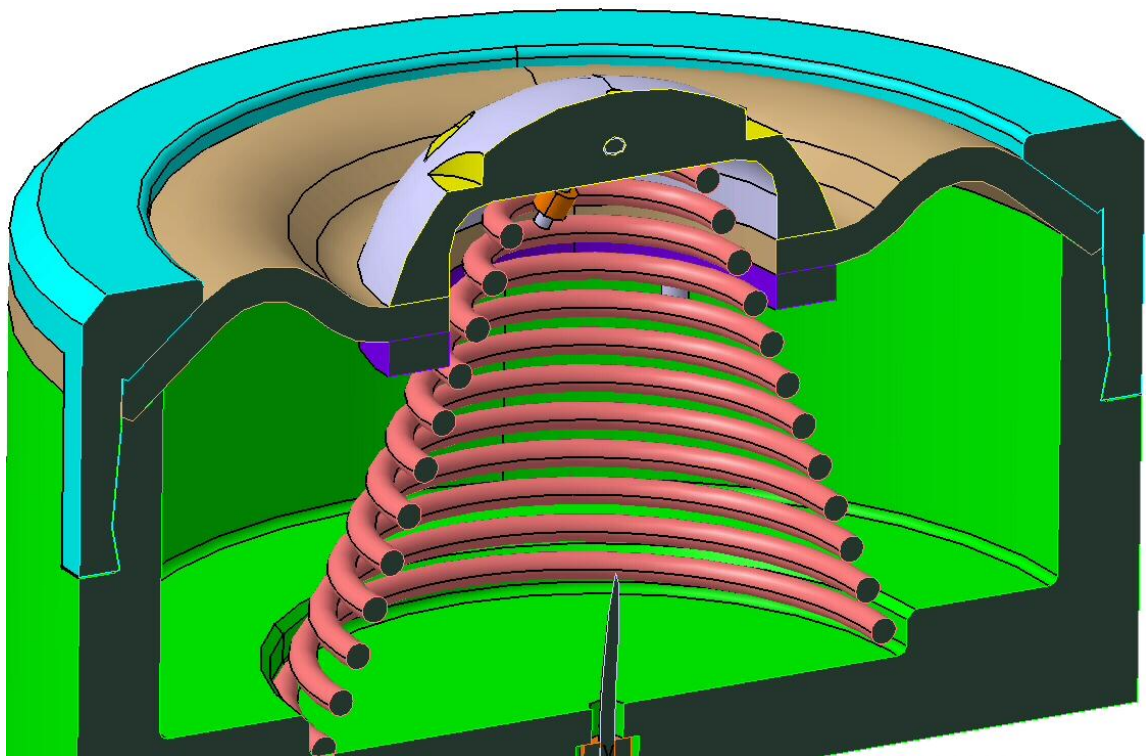

20

25

5

10

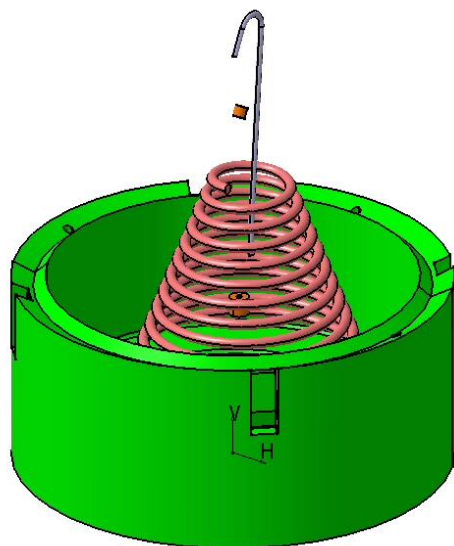
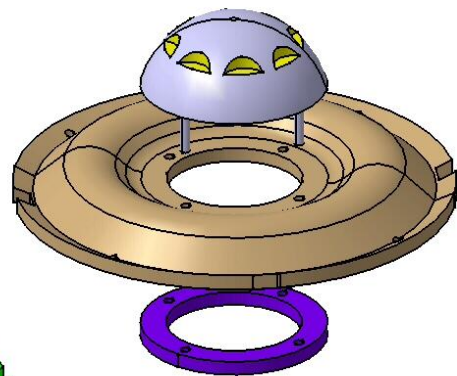
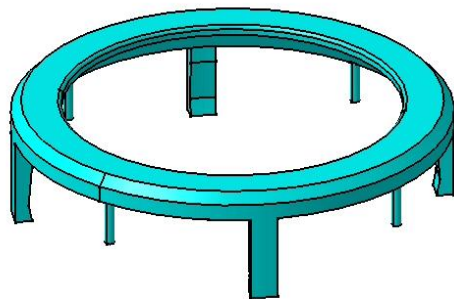

15

20

5

